

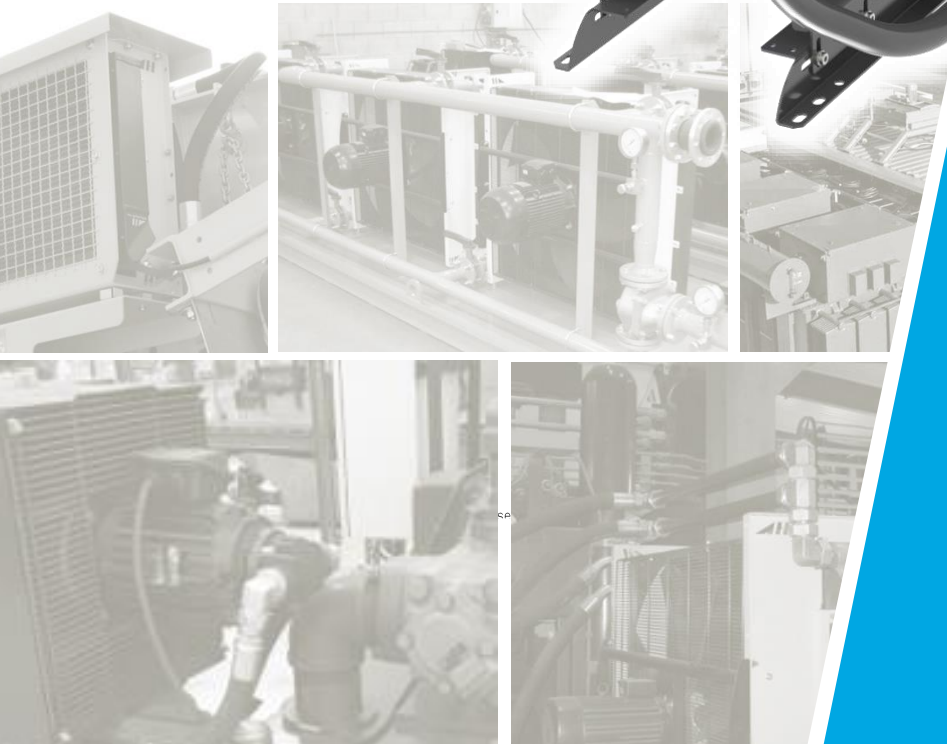

Thermal Systems

OFFLINE Coolers / Air Cooled Range

CC-2 Rail 35-102 lpm

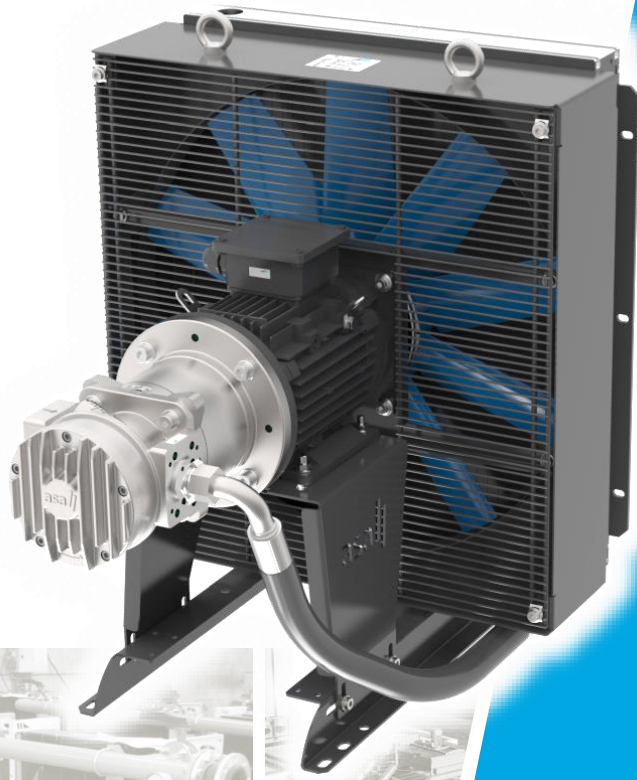

OFFLINE Coolers

Air Cooled Range / CC-2 Rail / 35-102 lpm



General Data and Details

The oil / air coolers of our CC series are autonomous cooling systems with an integrated circulation pump. They work as a separate cooling unit or as a filter cooling unit with an adequate filter. The benefits of such circulation coolers are a constant cooling performance and a higher durability, because there are no pressure vibrations or peaks in the cooler unit.

Conditions of use:

Maximum oil temperature: 80°C, maximum air temperature: 50°C. Motors can be used up to an altitude of 1.500m. For other conditions of use please contact our engineers.

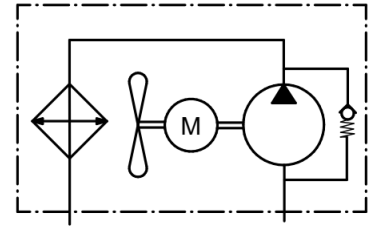

Connection

The **asa** rail system is the first worldwide flexible mounting and connection system for air blast heat exchangers. It gives you the free choice of the connector direction through turnable ports. The rail slots in the radiator are the frame structure not only for connecting the ports, also for various possible mounting arrangements such as bypass systems, mounting of the cooler to aggregates, measurement devices and much more. Please contact us to discover the huge potential of this system for your application.

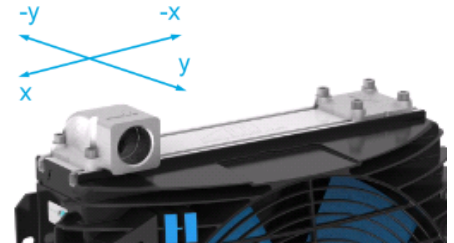

Scale Drawing

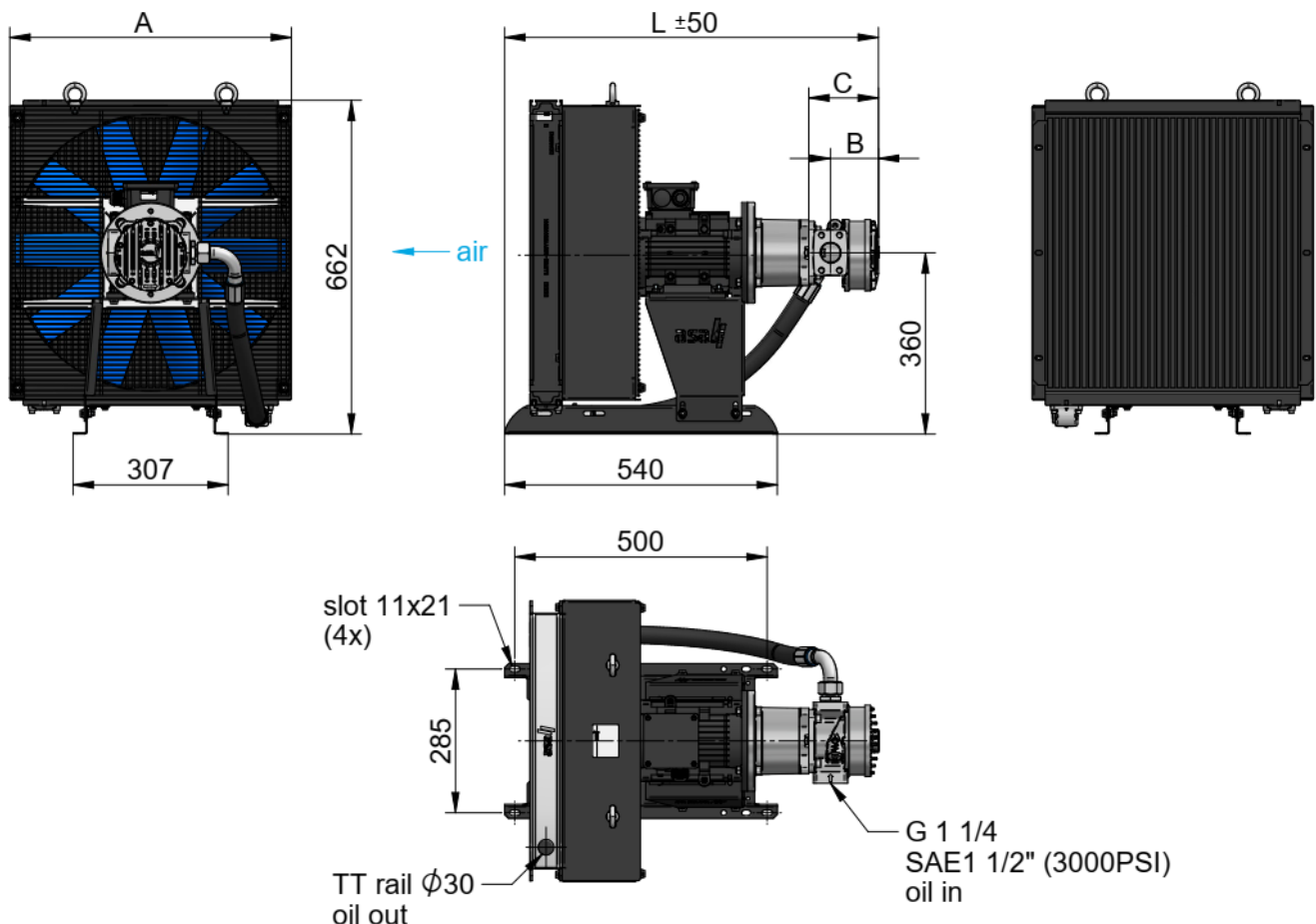

Dimensions

order number	description	A	B	C	L	weight
		[mm]	[mm]	[mm]	[mm]	[kg]
ASATT21RA6AC4	TT 21 rail 230/400V 1,50kW 6-pol 40cc	558	85	128	760	73
ASATT25RA69C4	TT 25 rail 230/400V 1,10kW 6-pol 40cc	558	85	128	731	63
ASATT25RA69C8	TT 25 rail 230/400V 1,10kW 6-pol 80cc	558	107	150	753	65
ASATT36RA69C8	TT 36 rail 230/400V 1,10kW 6-pol 80cc	736	107	150	774	75
ASATT36RA69C6	TT 36 rail 230/400V 1,10kW 6-pol 60cc	736	96	139	763	73
ASATT36RA6AC8	TT 36 rail 230/400V 1,50kW 6-pol 80cc	736	107	150	803	86
ASATT25RA49C4	TT 25 rail 230/400V 1,50kW 4-pol 40cc	558	85	128	731	64
ASATT25RA49C6	TT 25 rail 230/400V 1,50kW 4-pol 60cc	558	96	139	742	65
ASATT25RA4AC8	TT 25 rail 230/400V 2,20kW 4-pol 80cc	558	107	150	782	73
ASATT36RA49C6	TT 36 rail 230/400V 1,50kW 4-pol 60cc	736	96	139	763	75
ASATT36RA4AC8	TT 36 rail 230/400V 2,20kW 4-pol 80cc	736	107	150	803	81
ASATT36RA4BC6	TT 36 rail 230/400V 3,00kW 4-pol 60cc	736	96	139	792	86
ASATT36RA4BC8	TT 36 rail 230/400V 3,00kW 4-pol 80cc	736	107	150	803	87



Performance

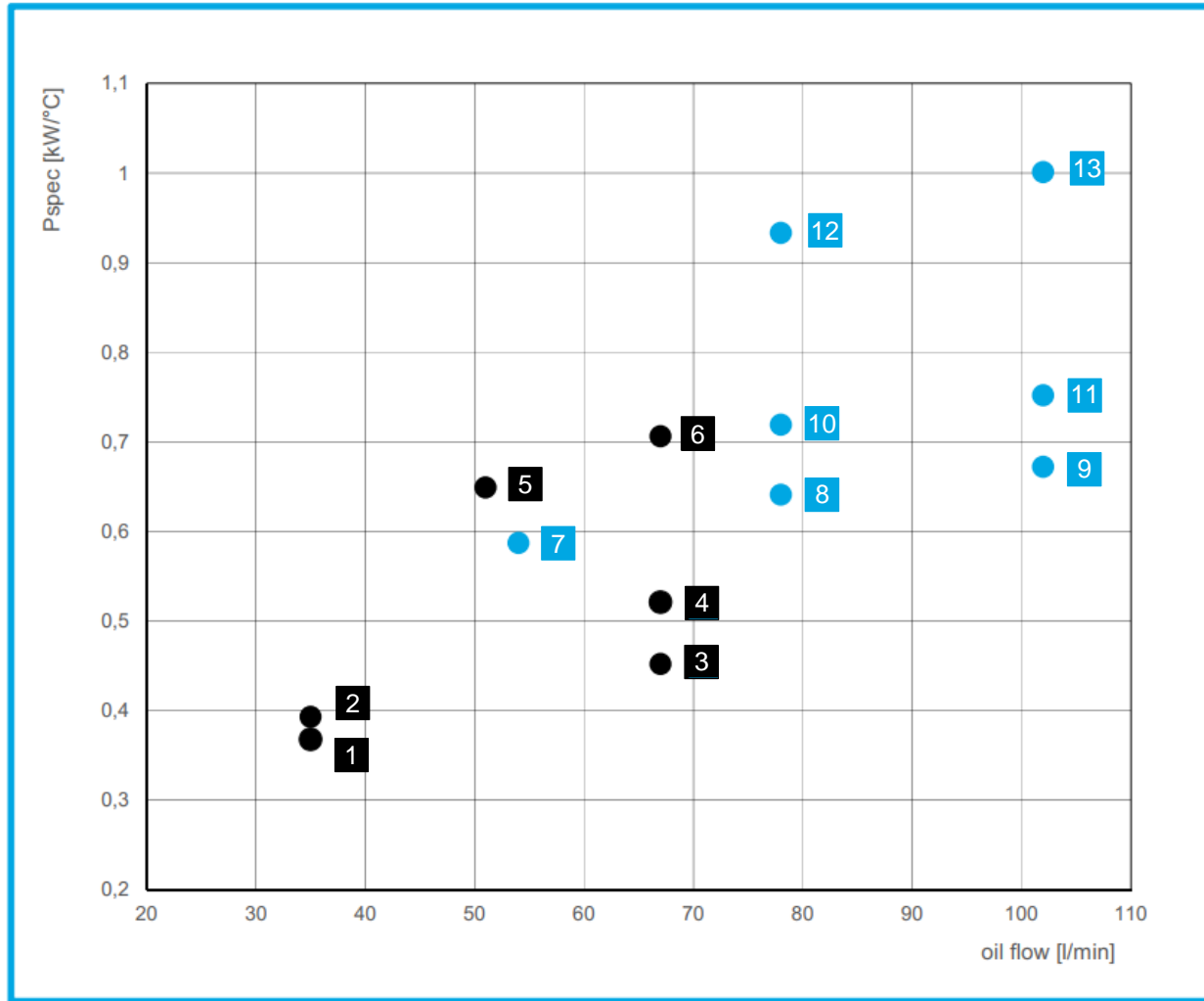

Technical Data

order number	description	oil flow	displacement	performance curve	max. working pressure	motor power	motor current	rotation	air flow	noise level
		[lpm]	[cm ³ /rotation]	see diagram	[bar]	[kW]	[A]	[rpm]	[kg/s]	[dB(A)]
ASATT21RA6AC4	TT 21 rail 230/400V 1,50kW 6-pol 40cc	35	40	1	6	1.50	6.3	950	1.19	65
ASATT25RA69C4	TT 25 rail 230/400V 1,10kW 6-pol 40cc	35	40	2	6	1.10	4.7	945	1.31	66
ASATT25RA69C8	TT 25 rail 230/400V 1,10kW 6-pol 80cc	67	80	3	6	1.10	4.7	945	1.31	68
ASATT36RA69C8	TT 36 rail 230/400V 1,10kW 6-pol 80cc	67	80	4	6	1.10	4.7	945	1.48	71
ASATT36RA69C6	TT 36 rail 230/400V 1,10kW 6-pol 60cc	51	60	5	6	1.10	4.7	945	2.32	73
ASATT36RA6AC8	TT 36 rail 230/400V 1,50kW 6-pol 80cc	67	80	6	6	1.50	6.3	950	2.33	72
ASATT25RA49C4	TT 25 rail 230/400V 1,50kW 4-pol 40cc	54	40	7	6	1.50	5.7	1445	2.02	79
ASATT25RA49C6	TT 25 rail 230/400V 1,50kW 4-pol 60cc	78	60	8	6	1.50	5.7	1445	2.02	79
ASATT25RA4AC8	TT 25 rail 230/400V 2,20kW 4-pol 80cc	102	80	9	6	2.20	7.9	1435	2.00	79
ASATT36RA49C6	TT 36 rail 230/400V 1,50kW 4-pol 60cc	78	60	10	6	1.50	5.7	1445	2.28	82
ASATT36RA4AC8	TT 36 rail 230/400V 2,20kW 4-pol 80cc	102	80	11	6	2.20	7.9	1435	2.26	82
ASATT36RA4BC6	TT 36 rail 230/400V 3,00kW 4-pol 60cc	78	60	12	6	3.00	10.5	1435	3.61	84
ASATT36RA4BC8	TT 36 rail 230/400V 3,00kW 4-pol 80cc	102	80	13	6	3.00	10.5	1435	3.61	84

This data sheet and the corresponding scale drawings are to be used as a general guideline and technical overview of our products. Please contact us if more exact information is needed. As we are constantly improving our products, their characteristics, dimensions and weights may also change, although we do our best to incorporate these changes continually. asa assumes no liability for any information therein, any errors, omissions, misprints, nor any direct or indirect damages, losses or costs resulting therefrom. Any cooling performances and general technical values indicated in this catalogue are measured at a test bench according to asa testing procedures or calculated, based on such tests. They represent a basis for your product selection. Due to different conditions in testing and application environments the performance may also vary by +/- 15%. All sound values are determined in accordance with ISO 9614-2, DIN EN ISO 11203 accuracy class 3 or Machinery Directive 2006/42/EG and are A-rated. At some of the performance data, possible differences to competition data are possible. The reason to that are no existing standardized testing procedures on individual subjects, e.g. for cooling performance measurements. Therefore, we recommend all products to be checked under the system operating conditions. This is also true of vibrations and mechanical stress as well as for pressure peaks and thermal stress and any other relevant factors. General tolerances according to DIN ISO 2768-vL. General tolerances for casted parts according EN ISO 8062-3 (DCTG 10). Tolerances for rubber parts are according to ISO 3302-1 (class M4-F+C). The tolerances of welding seams are defined by quality group D according to EN ISO 10042, if it is not specified on the actual scale drawing or data sheet. Any form of liability is excluded for the information included in this datasheet. All details and calculation values are checked to the best of our ability, but these do not ensure any intrinsic product properties: due to the wide-ranging possible applications, it is advised that all technical data herewith included be confirmed through testing carried out by the end-user. asa technology Produktions- und Vertriebs GmbH reserves the right to modify the product without any separate notification. This refers to both technical data and the product itself. Furthermore, it is herewith specified that the datasheet does not substitute the corresponding scale drawings, assembly and installation guidelines, nor the operating instructions.

DD-CC-2-TT-Rail-en-rev1 © asa technology, September 2022 page 4/8

OFFLINE Coolers

Air Cooled Range / CC-2 Rail / 35-102 lpm



Design

radiator material	aluminium
radiator air fin shape	wavy
pump type	gerotor
pump material (housing)	aluminium
sheet metal material	coated steel

Compatibility

max. kinematic viscosity:	up to 500 mm ² /s (depending on motor power)
suitable fluids	mineral oil acc. DIN51524

Connection (BSP 1")

ILLZATT53G25K	requires 1pc per cooler
---------------	-------------------------

Options

asa rail connector	ILLZATT53G32K (BSP 1 ¼")
temperature switch	ILLZTH4765K (50°C) ILLZTH6065K (60°C)
Rail filter	integrated spin on filter (page 6)
motor data	alternative voltages, frequencies, protection levels, etc on request
temperature bypass	for asa rail system (page 7)



OFFLINE Coolers

Air Cooled Range / Options



System for Rail Series

The H-Set is an optional system to integrate another hydraulic set to the asa rail system. The H-Set currently offers 2 sizes of kits to mount a spin on filter to the cooler application. This is a very compact and cost efficient integration. This system can also be combined with various other filters or the shown configurations. Contact us for further options and assistance to select the optimal product for you.

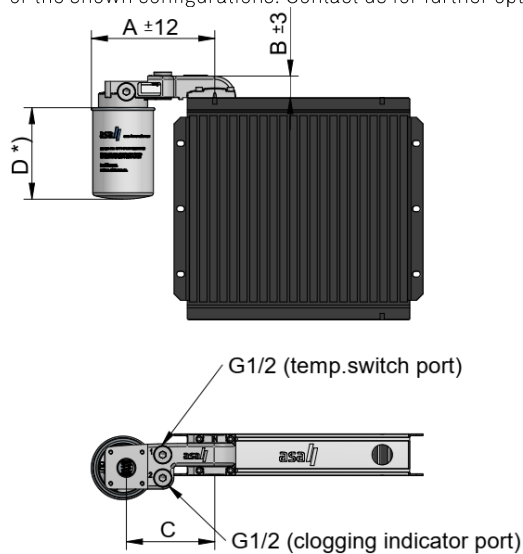

*) depending on the make of the filter element

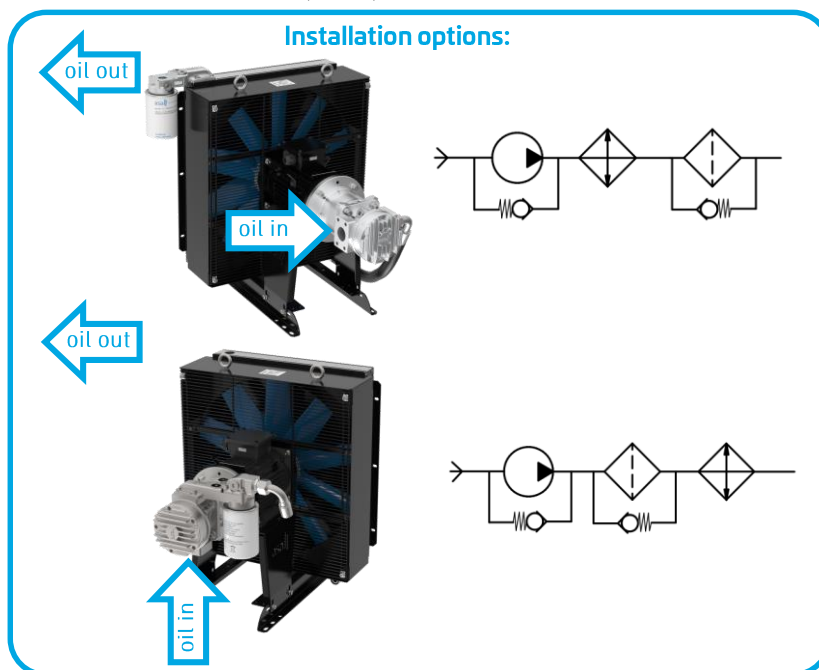

Dimension

order number	description	filter rating	working pressure	bypass incl.	spin on port	A	B	C	D
		[μm]	[bar]	[bar]	[BSP]	[mm]	[mm]	[mm]	[mm]
ILLZRF11G2010	Spin on filter kit rail 10 μm , 60lpm	10	10	2	3/4"	188	33	135	146
ILLZRF11G2025	Spin on filter kit rail 25 μm , 60lpm	25	10	2	3/4"	188	33	135	146
ILLZRF12G2010	Spin on filter kit rail 10 μm , 100lpm	10	10	2	3/4"	188	33	135	191
ILLZRF12G2025	Spin on filter kit rail 25 μm , 100lpm	25	10	2	3/4"	188	33	135	191
ILLZRF21G3210	Spin on filter kit rail 10 μm , 180lpm	10	10	2	1 1/4"	228	47	160	181
ILLZRF21G3225	Spin on filter kit rail 25 μm , 180lpm	25	10	2	1 1/4"	228	47	160	181

Rail-filter Block

material:	aluminium
working temperature range:	-20°C to +100°C (oil temperature)*
Sealing to rail flange:	o-ring NBR
bypass:	incl. 2 bar standard setting

Hydraulic Connection

compatible to	any rail system cooler
---------------	------------------------

Application

main application	offline circuits, lubrication, cooling and filtration circuits
oil flow	from cooler to filter

Options

temperature switches	ILLZTH4765K, ILLZTH6065K ILLZTH5069K
clogging indicator / indication pressure 1,5 bar	electric: HFZVEG15K N.O. & N.C.contact optical: HFZVOG15K

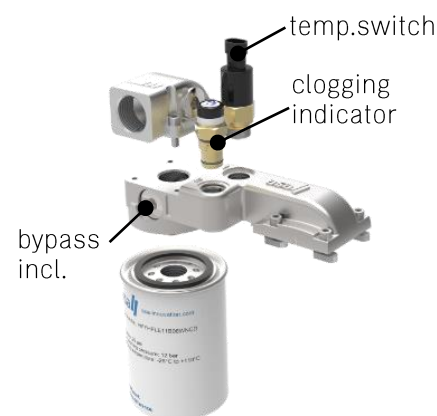

*...the indicated temperature is the maximum inlet temperature for the cooler radiator. Depending on the sealings in use, the application needs appropriate checking.

OFFLINE Coolers

Air Cooled Range / Options



The thermal bypass valve is an accessory to our oil/air coolers with the asa rail system, also for easy retro fit on existing coolers in the field with internal bypass.

The function is to keep the cooling performance to a minimum on a permanent fan drive system avoiding unwanted cooling at cold start conditions. The valve opens the bypass channel below 50°C and closes for maximum oil flow through the oil channels above 50°C to 60°C. Moreover the function of a spring loaded bypass valve is also integrated to protect the radiator core in case of overpressure and high return oil flows e.g. when differential cylinders are used.

Dimension on top of cooler

(mounted on asa rail system)

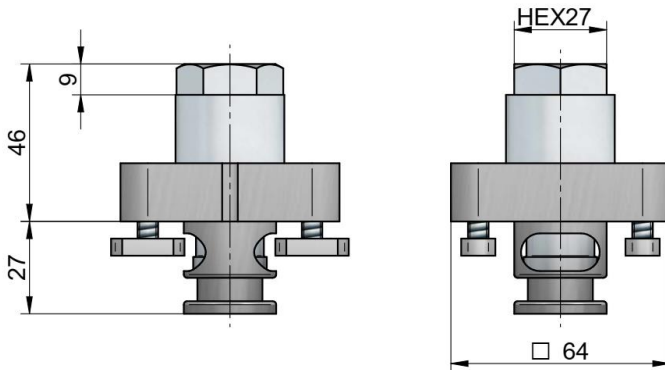

Technical Data

order number	description	max. working temperature	relief temperature	closing temperature	relief pressure	max. working pressure (static)	weight
			[°C]	[°C]	[bar]	[bar]	[kg]
ILLZBPT5027K	thermo-BP valve 50°C TT16-TT25	80°C	< 58	50 to 60	2*	26	0,42

*...opens only if temperature bypass is closed ($\geq 60^{\circ}\text{C}$)

Materials

sealings	HNBR
rail flange	aluminium
corrosion protection	all exposed surfaces:
temperature valve	zinc-nickel plated

Availability

ILLZBPT5027K	rail system coolers TT 21, TT25, TT36
--------------	--

Compatibility

minimum fluid cleanness	class 20/18/15 acc. ISO 4406:1999
viscosity range:	10...500mm ² /s (cSt) recommended 15...250mm ² /s (cSt)

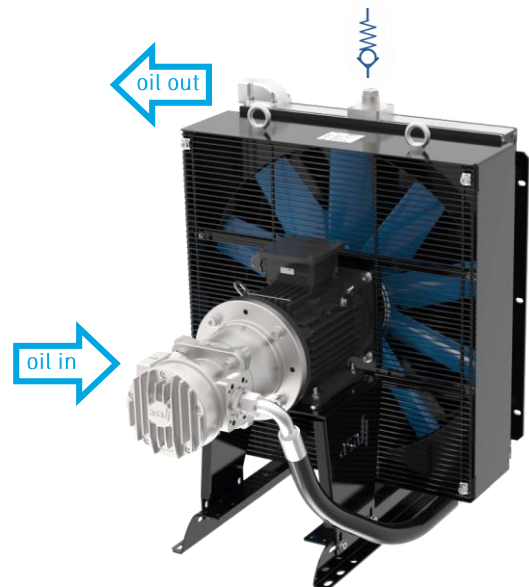
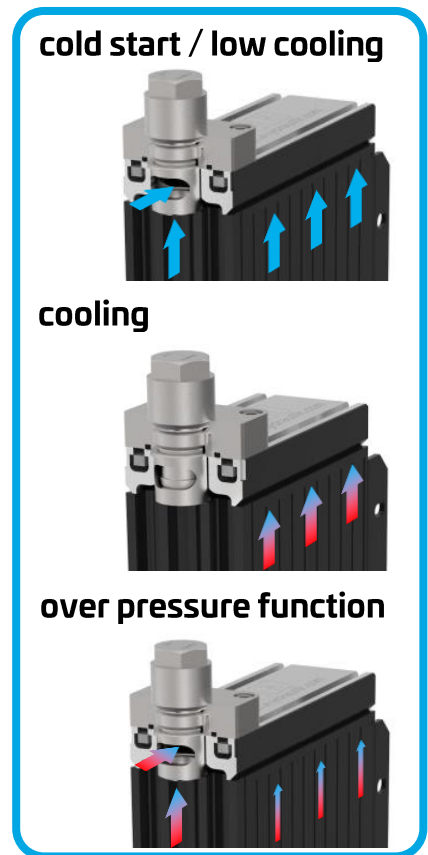

**be different.
make a difference.**



AUSTRIA

asa technology Produktions-
und Vertriebs GmbH
Prager Strasse 280
A-1210, Vienna
Tel.: +43 1 292 40 20
support@asahydraulik.com

AUSTRALIA

asa Products Pty Ltd
Quinlan Road 23
3076 Epping, Victoria
Tel.: +61 3 9397 6129
melbourne@asahydraulik.com

Brasil

asa hidráulica Ltda
Rua Maria Fett 96
03263-000 Vil Mercedes, Sao Paulo
Tel.: +55 11 9 8862-0022
salesbrazil@asahydraulik.com

CHINA

asa Hydraulik Technology (Suzhou) Co.Ltd
江苏省苏州市工业园区方洲路128号6区B幢
Area 6, Building B,
Fangzhou Road No 128,
Suzhou industrial park,
Suzhou City, Jiangsu Province
Tel.: +86 512 62381988
suzhou@asahydraulik.com

INDIA

asa heatexchanger Pvt Ltd
Plot no.1226, Phase-3, GIDC, Vatva
Ahmedabad - 382445
Tel.: +91 70 43907273
salesindia@asahydraulik.com

USA

asa hydraulik of America
160 Meister Avenue 20 A
Branchburg, New Jersey 08876
Tel.: +1 800 473 94 00
Tel.: +1 908 541 15 00
sales_us@asahydraulik.com